

frontrow™
togo

USER GUIDE

925RS Speaker

925T Body-worn Transmitter

925H Handheld Transmitter

925C Transmitter Charger



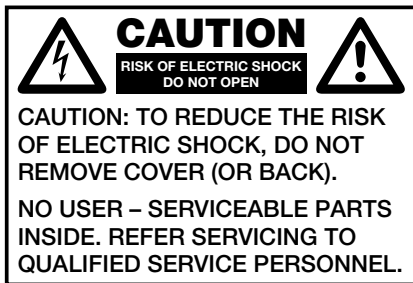

The lightning flash with Arrowhead Symbol within an equilateral triangle is intended to alert the user to the presence of “uninsulated” dangerous voltage” within the product’s enclosure that may be of sufficient magnitude to constitute a risk of electric shock to persons.



The exclamation point within an equilateral triangle is intended to alert the user to the presence of important operating and maintenance (servicing) instruction in the literature accompanying the appliance.

SAFETY INSTRUCTIONS & PRECAUTIONS:

IMPORTANT SAFETY INSTRUCTIONS

1. Read these instructions.
2. Keep these instructions.
3. Heed all warnings.
4. Follow all instructions.
5. Do not use this apparatus near water.
6. Clean only with dry cloth.
7. Do not block any of the ventilation openings. Install in accordance with the manufacturer's instructions.
8. Do not install near any heat sources such as radiators, heat registers, stoves, or other apparatus (including amplifiers) that produce heat.
9. Do not defeat the safety purpose of the polarized or grounding-type plug. A polarized plug has two blades with one wider than the other. A grounding type plug has two blades and a third grounding prong. The wide blade or the third prong are provided for your safety. When the provided plug does not fit into your outlet, consult an electrician for replacement of the obsolete outlet.
10. Protect the power cord from being walked on or pinched particularly at plugs, convenience receptacles, and the point where they exit from the apparatus.
11. Only use attachments/accessories specified by the manufacturer.
12. Use only with a cart, stand, tripod, bracket, or table specified by the manufacturer, or sold with the apparatus. When a cart is used, use caution when moving the cart/apparatus combination to avoid injury from tip-over.
13. Unplug this apparatus during lightning storms or when unused for long periods of time.
14. Refer all servicing to qualified service personnel. Servicing is required when the apparatus has been damaged in any way, such as power-supply cord or plug is dam-

- aged, liquid has been spilled or objects have fallen into the apparatus, the apparatus has been exposed to rain or moisture, does not operate normally, or has been dropped.
15. To Reduce The Risk Of Fire Or Electric Shock, Do Not Expose This Apparatus To Rain Or Moisture."
 16. Apparatus shall not be exposed to dripping or splashing and no objects filled with liquids, such as vases, shall be placed on the apparatus.
 17. Cart or Stand Assembly Instructions are packed with each cart or stand and provided with units.
 18. **WARNING:** To prevent injury, this apparatus must be securely attached to the wall in accordance with the installation instructions when stand not in use.
 19. Battery pack shall not be exposed to excessive heat such as sunshine, fire or the like.
 20. Do not use batteries that have been dropped or otherwise damaged.

ELECTRICAL SAFETY INFORMATION:

- A) Terminals marked with the  are considered **HAZARDOUS LIVE** and the external wiring connected to these terminals requires installation by an **INSTRUCTED PERSON** or the use of ready made leads or cords.
- B) The Front Row ToGo 925RS Receiver Speaker is built with the following electrical safety features:
 - Short circuit protection
 - AC input line fuse protection



PRECAUTIONS & SAFETY RECOMMENDATIONS

Follow Manufacturers' Recommendations

Before using the receiver, read all instructions and caution markings on the receiver and in this user guide.

ELECTRICAL WARNINGS:

DANGER! RISK OF ELECTRICAL AND FIRE HAZARD. MAY RESULT IN DEATH, SERIOUS INJURY, SHOCK OR BURNS.

TO HELP REDUCE THIS RISK:

This receiver, like all electrical products, MUST be treated with respect. Follow these instructions to reduce electrical hazard risk.

1. PROPER GROUNDING AND AC POWER CONNECTION

- o The receiver MUST be grounded to reduce risk of electric shock. The receiver is equipped with an electric cord having an equipment grounding conductor and a grounding plug. The plug MUST be plugged into an outlet that is properly installed and GROUNDED in accordance with all local codes and ordinances. If you ever feel even a slight shock from this or any electrical appliance, stop, walk away. Turn off electricity to outlet, and

have it inspected by an electrician. You may have a dangerous, improperly wired outlet.

- o **DANGER** - NEVER alter AC power cord or plug provided - if it will not fit in the outlet, have proper outlet installed by a qualified electrician or proceed as shown in the illustration below. Improper connection can result in a risk of an electric shock.

This battery the receiver is for use on a nominal 120 volt circuit (common household current), and has a grounding plug as illustrated. A temporary adapter may be used, USA only, to connect this plug to a two-pole receptacle, as shown, if properly grounded outlet is not available. The temporary adapter should be used only until a properly grounded outlet can be installed by a qualified electrician.

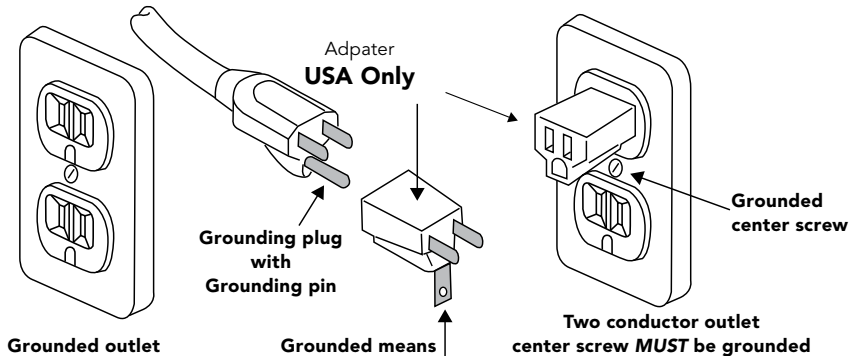

Using an adapter is forbidden in Canada. If a grounded outlet is not available, have one installed by a qualified electrician before using this charger.

DANGER - Before using adapter as illustrated, be certain that center screw of outlet plate is grounded. The green colored rigid ear or lug extending from adapter **MUST** be connected to a properly grounded outlet - make certain it is grounded. If necessary, replace original outlet cover plate screw with a longer screw that will secure adapter ear or lug to outlet cover plate and make ground connection to grounded outlet.

2. Avoid Abuse to the Receiver

- To reduce risk of electric shock, unplug the receiver from outlet before attempting any maintenance or cleaning. Turning off controls will not reduce this risk.
- **DO NOT** disassemble the receiver. Return the apparatus to Phonic Ear Front Row for qualified service and repair if service or repair is required.

ELECTRICAL WARNINGS: (cont'd)

Incorrect reassembly may result in a risk of electric shock or fire.

- o **DO NOT** expose the receiver to rain, snow, water, gas, oil, etc.
- o **DO NOT** operate the receiver if it has received a sharp blow, been dropped, or otherwise damaged in any way; return the apparatus to Phonic Ear Front Row for qualified service and repair.
- o **DO NOT** block or cover the apparatus and impeded ventilation.

3. Proper Use of The receiver and Wiring

- o An extension cord should not be used unless absolutely necessary. Use of improper extension cord could result in a risk of fire and electric shock. If extension cord must be used, use **ONLY** a grounded, 3-wire type cord. **NEVER** use a 2-wire cord and an adaptor! The cord **MUST** be

plugged into a grounded outlet. Make sure it is properly wired, in good electrical condition, and wire size is large enough for AC ampere rating of the receiver as specified below. AWG = American Wire Gauge

- o To reduce risk of damage to plug and cord when disconnecting the receiver, **ALWAYS** pull on plug - **NEVER** on cord.
- o Locate cord so that it will not be stepped on, tripped over, or otherwise subject to damage or stress. **DO NOT** lay extension cord on battery or the receiver. **DO NOT** operate the receiver with damaged cord or plug - replace them immediately.

Contents

Introduction	1
Understanding Active Learning.....	2
Chapter 1 Setup Tips	3 - 5
Chapter 2 Operation Tips	6 - 8
Chapter 3 Parts & Accessories	9 - 10
Chapter 4 System Features	11 - 16
Chapter 5 System Set-up.....	17 - 24
Chapter 6 Using your system.....	25 - 36
Chapter 7 Speaker Placement & Mounting	37 - 39
Chapter 8 Channel Mapping Tips	40 - 41
Chapter 9 Troubleshooting	42 - 43
Chapter 10 Speaker Battery Replacement.....	44
Chapter 11 System Specifications	45 - 48
Chapter 12 Regulatory Information	49 - 52

1

2

3

4

5

6

7

8

9

10

11

12

Introduction

Congratulations on the purchase of your new FrontRow To Go™ active learning system!

You may have heard the term 'sound field' used to describe technology that improves classroom acoustics. Your FrontRow system fits under this category, but we call it an 'active learning system' because the benefits affect much more than just sound.

Active learning systems can help engage students, improve attentiveness to the teacher, build learning success, reduce the achievement gap, foster control and orderliness, improve test scores, and reduce vocal strain and fatigue for teachers. Numerous studies show that classrooms using active learning enjoy better student comprehension, increased student participation, better grades and fewer behavioral referrals.

Read this manual carefully to become familiar with your system and to get the most out of its many features and options.

Understanding Active Learning and its Benefits

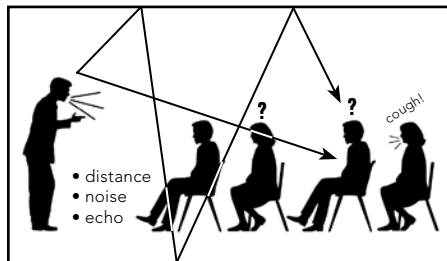

without active learning

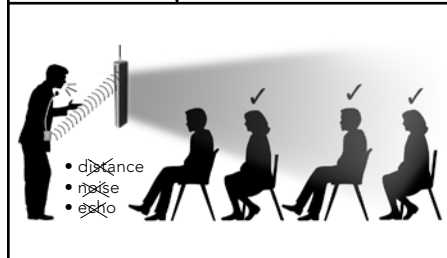

with active learning

1 Setup Tips

IMPORTANT!

Be sure to charge your FrontRow ToGo speaker (if purchased with battery) and transmitter units overnight – for a minimum of 12 hours – before turning the power on and/or using them for the first time. Failing to do so may reduce battery capacity.

Basic setup tips

First – Identify a front corner of the room – the location from where the teacher normally teaches.

Second – Take a good look around, paying close attention to power outlet and other electronic equipment locations. Ideally, the speaker should be placed at a 5 ft./1.5m distance from other electronic equipment, such as computers or radios.

Third – Determine whether to mount the speaker on the wall as shown (diagram 1), or place it on a sturdy surface using the table stand (diagram 2). In either case, the speaker

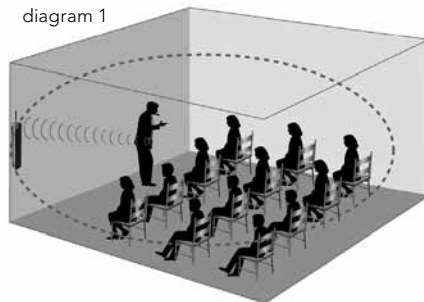

Setup Tips (cont'd)

should be placed at a height of 3 ft./1m from the floor, or at a level closest to the listener's ears.

Fourth – Consider whether other FrontRow ToGo, FrontRow Tempo, or other radio-based active learning systems are in use in the building, and set transmitter and receiver channels accordingly. Every transmitter in a building should be on its own channel. See diagrams on pages 40-41 for guidance.

diagram 2

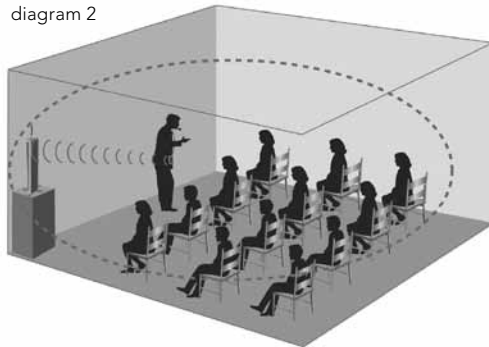

If placing the speaker on a table or surface top, consider the following:

- **Choose a location that provides easy access for the teacher, and is out of the way of students and main traffic areas.** The speaker should be placed at least 6 ft./1.8m away from where the teacher stands.

Setup Tips (cont'd)

- **Choose a table or surface top that is sturdy.** Make sure the table or cabinet is structurally solid, sturdy and out of the way of foot traffic.
- **Properly mount and securely fasten the table stand onto the bottom of the speaker.** Make sure the stand is fully open and screwed on tightly, and that the speaker does not wobble when in an upright position.

If mounting on the wall, consider the following:

- **The power supply cord needs to reach the wall outlet.** Make sure the power supply is within reach of the speaker in its wall-mounted position.
- **The teacher should be able to reach the controls located on top of the speaker once it's mounted.** Once the volume is set at a comfortable level, the speaker power switch located on the lower right side of the speaker can be easily accessed by the teacher. Follow the instructions on page 32 for setting the volume at the proper level.
- **Never mount the speaker upside down, or horizontally.** The speaker unit must be mounted so the controls are located at the top of the unit.

2 Operating Tips

In the morning –

- **Turn transmitter power 'on' and put microphone on.**
- **Turn speaker column power 'on'.** The speaker should remain plugged into a wall power outlet during the day – with the power in the 'on' position. Turn power switch to the 'off' position at night after each use. If your system has an internal battery, it is not being used while the speaker is plugged into a wall outlet.
- **To operate as a portable system,** if your system is equipped with an internal battery simply unplug the speaker before use and plug back in after use. The battery takes 8 hours to reach a full charge; at full charge, the speaker column battery will last up to 5 hours unplugged.

After each use –

- **Turn transmitter power 'off'**, and place it back onto the charging stand; confirm that the 'charge' indicator light illuminates. Transmitters not in use should always be placed on the charging stand.
- **Turn speaker column power 'off'.** Leave speaker plugged into wall power outlet, but confirm that the power has been turned 'off.'

Operating Tips (cont'd)

Battery care and maintenance tips –

- To maximize your battery operating time, "cycle" the battery (fully charge and fully discharge) five times during initial use.
- The speaker battery will last approximately 2 years depending on usage.
- When not in use, leave speaker plugged into wall outlet with power switch in 'off' position.
- Keep speaker away from heating units – use/store in a cool dry place.
- When using speaker battery power (unplugged from wall), always remember to return power switch to 'off' position after use.
- Never mount/use speaker horizontally or upside down. Controls should be accessible from top of unit.
- Remember to charge all rechargeable batteries overnight before initial use.
- Plan on buying new NiMH batteries for your transmitter every 12 months. Alkaline batteries can also be used as back-ups, however, the 925C charger will not charge alkaline batteries. Never attempt to charge alkaline batteries – this will cause damage to the unit and void the product warranty.

Operating Tips (cont'd)

Do not coil the microphone cord – since it also acts as your antenna, coiling or wrapping the cord around the transmitter will affect its range and may also reduce its life.

Speak at a normal level – the system is projecting your voice for you!

1

2

3

4

5

6

7

8

9

10

11

12

3 Parts & Accessories



Receiver

- 1 Column Speaker Receiver (925RS-216)
- 2 Receiver Antenna (AT0831)
- 3 Channel Changer Screwdriver (330-3000-101)
- 4 Speaker Table Stand (890-88-320-00)
- 5 Wall Mounting Bracket (Set of 2) (890-88-322-00)
- 6 Carrying Case (895-88-025-00)
- 7 Power Cord, Receiver (300-7402-110)
- 8 Audio Cable Kit - Aux Input/Output (392-88-108-00)
- 9 Volume Locks (x2) (543-88-020-00)

Parts & Accessories (cont'd)

925T



925H



925C

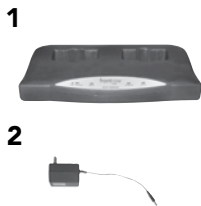

925T

- 1 Body-worn Transmitter (925T-216)
- 2 Behind The Neck Microphone (890-88-300-00)
- 3 Elastic Belt (AT0712)
- 4 AA Rechargeable NiMH Batteries (374-30-420-00)

925H

- 1 Handheld Transmitter (925H)
- 2 AA Rechargeable NiMH Batteries (374-30-420-00)

925C

- 1 Charging Stand (925C)
- 2 Power Supply, Transmitter Charger (AT0819)

4 System Features: Receiver



1. Channel A Channel Selector
2. Channel B Channel Selector
3. Antenna
4. Channel A On/Off/Volume
5. OptiVoice Selector
6. Aux-In Jack (3.5mm Mono)
7. Aux-In Volume
8. Aux-Out Jack (3.5mm Mono)
9. Aux-Out Volume
10. Channel B On/Off Volume
11. LED Indicators
12. Locator Hole



System Features: Receiver (cont'd)



1. Speaker Battery Charge Indicator
2. Main Power On/Off Switch
3. Power Cord Jack
4. Locator Hole
5. Screw Hole



System Features: 925T

front



back



System Features: 925T (cont'd)

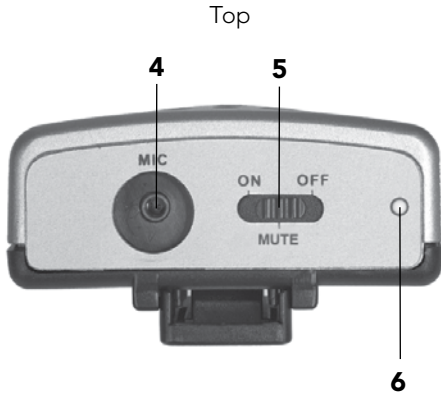

1. Belt clip
2. Battery compartment
3. Channel selector
4. Microphone input (2.5mm)
5. 3 position power switch
6. Power and low battery indicator light



System Features: 925H



1. LED indicator light
2. 3 position power switch
3. Channel selector
4. Battery compartment
5. Channel selector key
(inside battery compartment)



On



Mute



Off

System Features: 925C

Front

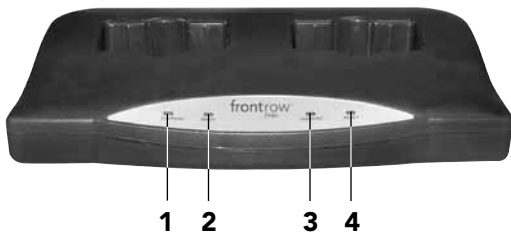

1. Pocket 1 charging indicator
2. Pocket 1 full charge indicator
3. Pocket 2 charging indicator
4. Pocket 2 full charge indicator
5. DC power jack

Back



5 System Setup: Receiver



1. Place speaker unit face down on a clean, flat surface
2. Open table stand arms
3. Place locator bolt of table stand into locator hole on the bottom of the speaker
4. Tighten fixing bolt to securely fix stand to unit
5. **CAUTION - This speaker for use only with stand packaged with unit. Use with other stands is capable of resulting in instability causing possible injury.**



System Setup: Receiver (cont'd)

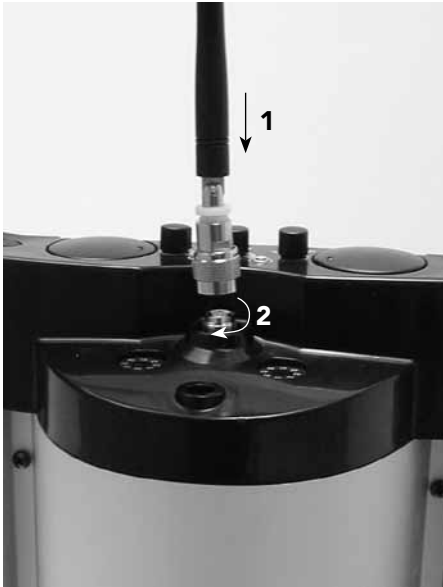

1. Attach antenna to top of speaker
2. Turn metal base of antenna clockwise until secured tightly (do not over-tighten)

System Setup: Receiver (cont'd)



If using wall outlet:

1. Plug power cord into power jack
2. Plug power cord into wall socket
3. Turn speaker **off**



System Setup: Receiver (cont'd)



If using battery power:

1. Plug power cord into power jack
2. Plug power cord into wall socket
3. Turn speaker **off**

Charge battery overnight before initial use.

Red light = charging

Green light = fully charged

Recharging time is approximately 8 hours for a full charge.

NOTE: Light is not illuminated during battery operation

System Setup: 925T

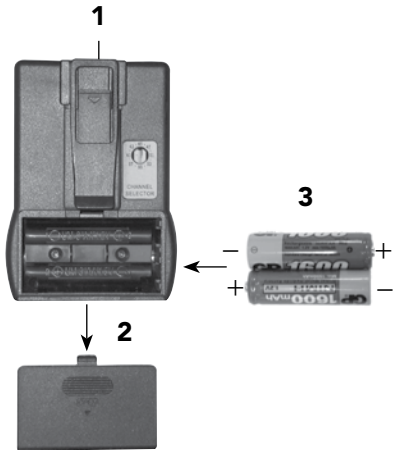

1. Switch power **off**
2. Remove battery cover
(push and slide off)
3. Insert two AA rechargeable
NiMH batteries

WARNING: Never recharge alkaline batteries! This will cause damage to the unit and will void the product warranty.

System Setup: 925H



1. Switch power **off**
2. Remove battery cover (turn counter-clockwise)
3. Insert two AA rechargeable NiMH batteries

WARNING: Never recharge alkaline batteries! This will cause damage to the unit and will void the product warranty.

System Setup: 925C

charger back

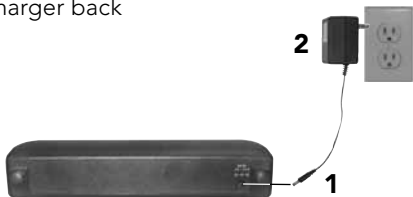

1. Plug power supply into power jack on back of charger stand
2. Plug power supply into wall socket
3. Turn transmitters **off** and place into charger

charger front



WARNING: Never recharge alkaline batteries! This will cause damage to the unit and will void the product warranty.

System Setup: 925C (cont'd)



1. Charging:

Red light = units are being charged

Blinking red light = charging error. Improper batteries have been detected. Check your batteries and replace as required. Only NiMH AA batteries can be charged. Unit will not charge disposable Alkaline batteries or NiCad batteries.

2. Ready:

Green light = units are fully charged

6 Using Your System

925T



925H

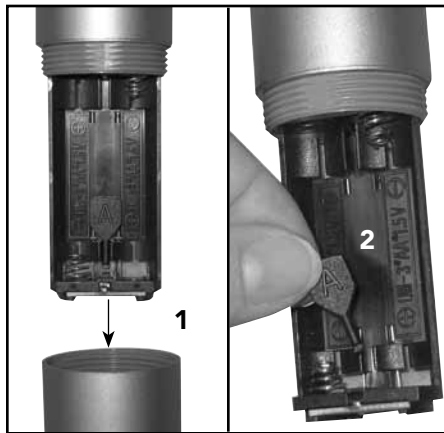

1. Open battery compartment door and remove batteries
2. Remove channel adjustment key

Using Your System (cont'd)



1. Use a screwdriver to turn frequency selector to channel number that matches the channel on column speaker
2. If using both body-worn and hand-held transmitters set one transmitter channel to match **Channel A** on the speaker column, and the other transmitter channel to match **Channel B** channel on the speaker column.

NOTE: Never operate two transmitters on the same channel or interference will result.

Using Your System (cont'd)



1. Plug microphone cord into mic jack on top of body-worn transmitter

Using Your System (cont'd)

Put on microphone and adjust for proper distance from mouth. Maximum distance from mic to mouth is 6 in./15cm; 3 in./7.5cm is ideal.



Using Your System (cont'd)

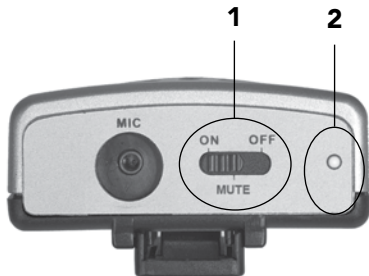

1. Switch power **on**
2. Check indicator light:
Continuous green = adequate power
Continuous red = low battery

Battery Life

NiMH rechargeable AA = ~12 hours
Alkaline disposable AA = ~15 hours

Using Your System (cont'd)

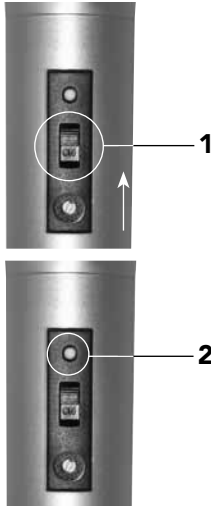

1. Turn power **on**
2. Check indicator light:
Continuous green = adequate power
Continuous red = low battery

Battery Life

NiMH rechargeable AA = ~12 hours

Alkaline disposable AA = ~15 hours

Using Your System (cont'd)



1. Turn main power **on**
2. Turn channel **on** by turning **Channel A** and/or **Channel B** volume control knob(s) (remember that main power must also be on)

3. LED Indicators
Green = on & receiving FM signal
Red = on & NOT receiving FM signal

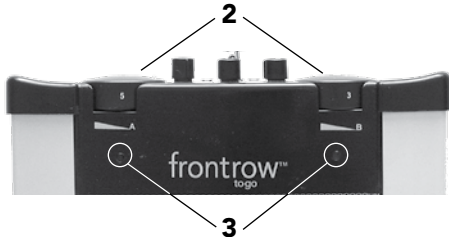

Using Your System (cont'd)

Follow steps **1** or **2** below to adjust **FM volume** setting to proper level. Two people are needed to set the volume level. It is difficult to hear your own voice and make adjustments to it.

NOTE: The average volume setting is in the 3 position (see photo), but may change depending on room acoustics and noise level.



1. With a sound level meter - Take a level reading in the center of the room during normal classroom activity, and another reading of the teacher's amplified voice (without the class activity). The level of the teacher's voice should be set between 10-15 decibels above room noise level.

2. Without a sound level meter - First, ask someone other than yourself (if you are the teacher) to listen to the amplified voice and make volume adjustments. An ideal volume level is achieved when the listener can hear the amplified voice at a comfortable level and the volume level from the speaker and teacher's mouth is comparable. If you can hear yourself through the loudspeakers, the volume setting may be too high and should be decreased.

Using Your System (cont'd)

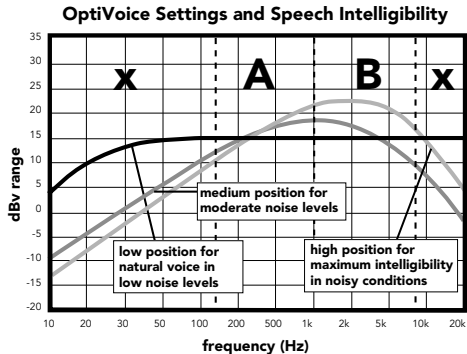

OptiVoice is a 3-position switch that automatically adjusts the sound quality of the primary speaker's voice. It allows teachers to shape the sound of their voice and helps to ensure maximum speech clarity in low, medium and high noise levels.

- A** Lower frequencies provide warmth and personality but can mask the higher frequencies critical to intelligibility
- B** Critical speech intelligibility range (primarily consonants)
- X** Contains little useful speech information

Using Your System (cont'd)

1. Set **OptiVoice** switch according to room noise level. **Medium** position is the recommended setting for average noise levels.

Low: Use in low-noise situations and for most natural voice reproduction.

Medium: Best setting for average classrooms where low-medium noise levels are present.

High: Use in high noise levels. Helps to ensure top comprehension during critical tasks such as test-taking or hearing impaired instruction.

NOTE: With each increase in level, there is an increase of approximately 3dB in gain (volume). This may require a decrease in the receiver volume setting to avoid potential microphone/speaker feedback.

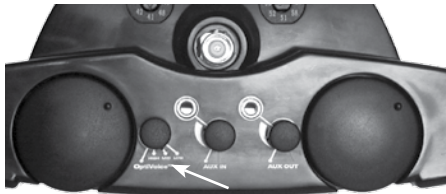

Using Your System (cont'd)



1. Using the appropriate adaptor cords, connect VCR, TV, CD, computer or other audio source to Aux-In port on top of speaker.
2. Use Aux-In Volume control to adjust volume

NOTE: Aux-In can be used simultaneously with both Channel A & B.

Using Your System (cont'd)

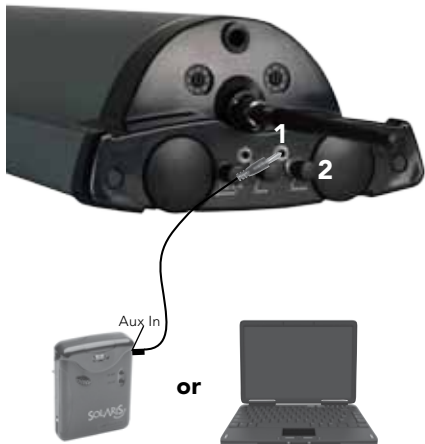

Aux out – connecting to computers or personal FM devices

Use this to connect to a computer (to record audio for podcasting) or to a personal FM system (a device for the hearing impaired)

1. Connect cord to aux-out jack on the ToGo to the aux-in jack on the other device.
2. Adjust the aux-out volume on the ToGo accordingly

7 Speaker Placement & Mounting

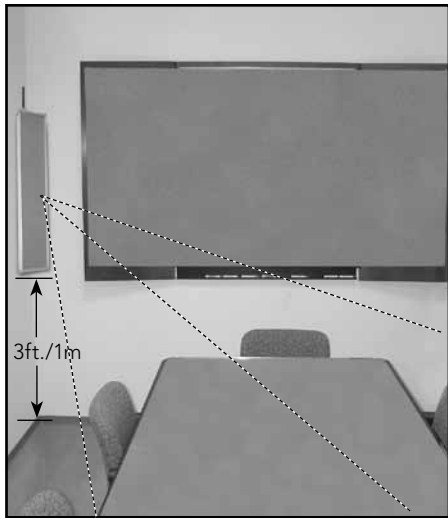

Place speaker in a corner of the room facing listeners. Mount speaker on wall using brackets or place speaker on a surface using a speaker stand. The bottom of the speaker should be about 3 ft./1m from the floor. (See setup tips on page 3).

Speaker Placement & Mounting (cont'd)



1



2



3

Without Mounting Template:

1. Measure 36" from the floor (maximum height) to the bottom of the lower bracket and mark mounting screw holes to be drilled.
2. Attach lower bracket to wall – If mounting to drywall, use 5 - #10 self-threading 1.25" flathead phillips screws with drywall anchorsA
3. Place speaker on lower bracket and hold in place. Be sure the locator hole on the bottom of the speaker is securely mated with bolt in the lower bracket
4. Insert upper bracket into the locator hole on the top of the speaker and place against the wall. Do not depress the spring on the upper bracket. Mark the upper bracket holes, then carefully remove the speaker from the bottom bracket. Attach upper bracket to wall

Speaker Placement & Mounting (cont'd)

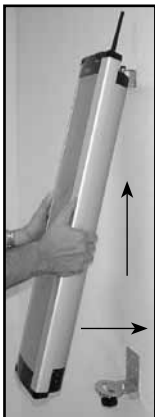

4



5

5. Attach speaker to wall mount by inserting the upper bracket into the locator hole in the top of the speaker. Gently lift the speaker upwards and forward, mating the locator bolt on the lower wall mount bracket with the locator hole on the bottom of the speaker
6. Move swivel arm to align screw holes. Screw in fixing bolt through the swivel arm and into the screw hole in bottom of speaker. Tighten.

To remove unit from wall mount, simply unscrew the fixing bolt and lift the speaker up and out.

WARNING:

To prevent injury, this apparatus must be securely attached to the wall using the wall brackets and mounting screws or with the floor stand supplied with the purchase of this system, both of which must be securely fastened by the fixing bolt.

8 Channel Mapping Tips

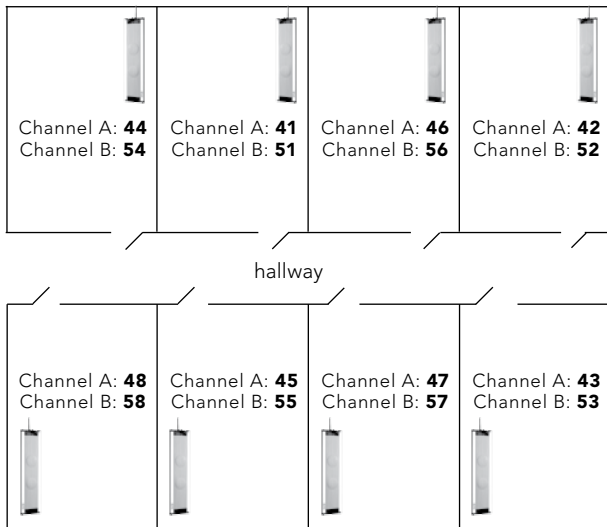

 = suggested placement of 925RS-216 speaker

Channel Mapping Tips (cont'd)

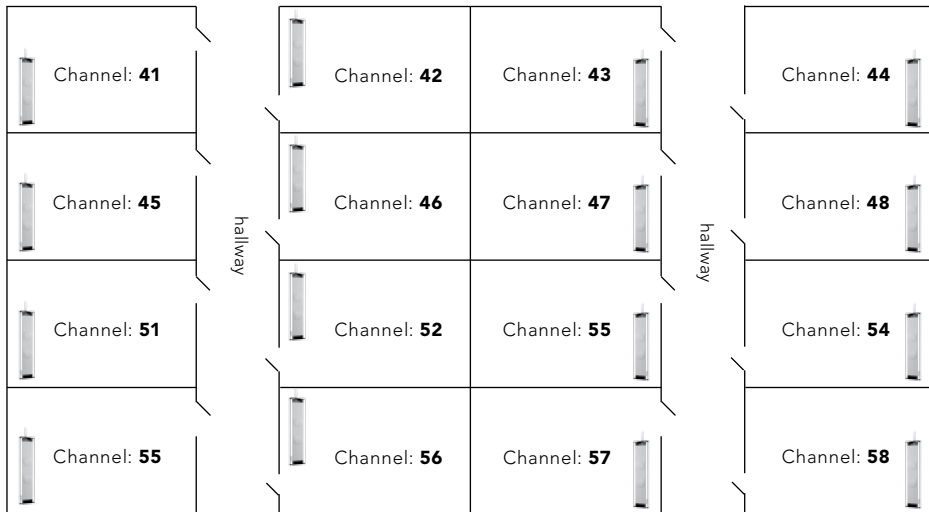

9 Troubleshooting

no FM reception (Channel A, Channel B indicator does not have green light)

- Verify the transmitter is turned on
- Verify the frequency number on the transmitter matches the frequency number on receiver
- Verify transmitter batteries are charged
- Verify speaker antenna is connected properly

weak sound from speaker

- Increase volume on the speaker
- Turn up transmitter volume
- Make sure the boom microphone (or other mic) is being worn correctly

speaker is receiving a signal but no sound is coming out

- Verify microphone is connected properly to transmitter and is working correctly

feedback from speaker

- Turn down the volume on the speaker
- Make sure the person wearing the transmitter is not too close to the speaker
- Move speaker so that it is facing away from presenter and toward listeners
- Make sure the boom microphone (or other mic) is being worn correctly

troubleshooting (cont'd)

speaker does not turn on

- Verify main power switch on the bottom of the unit is turned on
- Verify Channel A and Channel B volume control knobs are turned on
- Verify power supply is plugged securely into speaker and wall socket
- Verify wall socket works

speaker battery does not charge

- If using unplugged from wall outlet, verify battery is installed. If installed, verify it has been charged. If it does not charge, see below.
- Connect power supply to speaker and charge for four hours. If speaker battery does not hold a charge, contact FrontRow Service department for

replacement (battery should be replaced after one year of continuous use).

speaker is picking up FM interference or hum

- Check to make sure no other wireless systems are operating on similar frequencies
- Check to make sure the system is not placed too close to a computer
- Check to make sure metal objects are not placed too close to transmitter or speaker (i.e. jewelry, metal shelves)

red charge light is flashing when I attempt to charge my transmitter

- Replace your batteries with a set of new NiMH cells.

10 Speaker Battery Replacement/Installation



1. Turn off main switch and disconnect the power cord from the wall outlet and the rear base of the apparatus.
2. Remove 4 hex screws (3mm) on bottom and remove panel
3. Disconnect old battery and replace with new battery. Replace panel and 4 hex screws. Do not over tighten screws.
4. To maximize your battery operating time, "cycle" the battery (fully charge and fully discharge) five times during initial use

CAUTION:

Danger of explosion and damage to the receiver may result if the battery is incorrectly replaced. Replace only with the recommended type NiMH battery pack sold by Front Row.

DISPOSAL/ENVIRONMENT:

Disposal of old batteries must be done in accordance and with regards to all applicable and local environmental laws, regulations and codes. Always dispose batteries in an environmentally safe manner.

11 System Specifications

Channel #	Channel A	Channel #	Channel B
41	216.025 MHz	51	216.525 MHz
42	216.075 MHz	52	216.575 MHz
43	216.125 MHz	53	216.625 MHz
44	216.175 MHz	54	216.675 MHz
45	216.225 MHz	55	216.725 MHz
46	216.275 MHz	56	216.775 MHz
47	216.325 MHz	57	216.825 MHz
48	216.375 MHz	58	216.875 MHz

System Specifications (cont'd)

two channel column speaker: 925RS-216

Carrier Frequency Range	216 - 217MHz
Modulation	FM (F3E)
Output Power	Maximum 36W RMS @ 4 Ω x 2
Power Requirements	AC 110-200V ~50-60Hz, 1A max
Battery	1 x NiMH rechargeable
Frequency Response	100Hz –9kHz (at rated output)
Total Harmonic Distortion	<1% (at rated output) @ 1kHz
System signal-to-noise ratio	>70 dB (at rated output)
Inputs	1 x aux-in, 3.5 mm mono
Output	1 x aux-out, 3.5 mm mono
Controls	Channel A/B on/off/volume Channel A/B channel selector aux-in volume, aux-out volume, OptiVoice main power

Dimensions (wxhxD)	29.5 x 7.2 x 3.4 in 750 x 183 x 85 mm
Weight	12.5lbs. / 5.7 kg
Battery life	5 hours (rechargeable)
Recharging time	8 hours

System Specifications (cont'd)

Body-worn Transmitter: 925T

Carrier Frequency Range	216 - 217MHz
Modulation	FM (F3E)
Operating Range	>110ft./34m
RF Output	<15mW
Total Harmonic Distortion	<0.5%
Dynamic Range	100dB
Dimensions (WXHXD)	2.5 x 3.5 x 1 in. 65 x 90 x 25 mm
Weight	1.8oz / 51g
Controls	On/Mute/Off Channel selector
Inputs/Outputs	2.5mm mic input jack
Battery Type	2 AA (LR6) NiMH rechargeable (1600mA) or 2 AA (LR6) alkaline disposable
Battery life	12 hours (rechargeable) 15 hours (alkaline)
Recharging time	6 hours

Handheld Mic Transmitter: 925H

Carrier Frequency Range	216 - 217MHz
Modulation	FM (F3E)
Operating Range	>110ft. / 34m
RF Output	<15mW
Total Harmonic Distortion	<0.5%
Dynamic Range	100dB
Dimensions (DIA.XH)	2.1 x 9.3 in. 54 x 237 mm
Weight	8.1oz / 230g
Controls	On/Mute/Off Channel selector
Battery Type	2 AA (LR6) NiMH rechargeable (1600mA) or 2 AA (LR6) alkaline disposable
Battery life	12 hours (rechargeable) 15 hours (alkaline)
Recharging time	6 hours

System Specifications (cont'd)

Charging Stand: 925C

Power Supply	AC adaptor (DC 12V/0.5A)
Indicator lights	Power = red LED Charging = red LED Ready = green LED Charging Error = blinking red LED
Dimensions (wxhxd)	1.9 x 5.3 x 9 in 135 x 47 x 230 mm
Weight	12.7oz / 360g

1

2

3

4

5

6

7

8

9

10

11

12

12 Regulatory

Transmitter

This transmitter is authorized by rule under the Low Power Radio Service (47 C.F.R. Part 95) and must not cause harmful interference to TV reception or United States Navy SPASUR installations. You do not need an FCC license to operate this transmitter. This transmitter may only be used to provide: auditory assistance to persons with disabilities, persons who require language translation, or persons in educational settings; health care services to the ill; law enforcement tracking services under agreement with a law enforcement agency; or automated maritime telecommunications system (AMTS) network control communications. Two-way voice communications and all other types of uses not mentioned above are expressly prohibited.

This device may not interfere with TV reception or federal government radar, and must accept

any interference received, including interference that may cause undesired operation.

IMPORTANT NOTE: To comply with FCC RF exposure compliance requirements, only use supplied antenna that is sold with this transmitter. Use of any other antenna which has not been approved by the manufacturer will violate FCC rules and regulation and void the user's authority to operate this device. This device and its antenna(s) must not be co-located or operating in conjunction with any other antenna or transmitter.

Regulatory (cont'd)

receiver: part 15, subpart B



This equipment has been tested and found to comply with the limits for a Class B digital device, pursuant to Part 15 of the FCC Rules. These limits are designed to provide reasonable protection against harmful interference in a residential installation. This equipment generates, uses and can radiate radio frequency energy and, if not installed and used in accordance with the instructions, may

cause harmful interference to radio communications. However, there is no guarantee that interference will not occur in a particular installation. If this equipment does cause harmful interference to radio or television reception, which can be determined by turning the equipment off and on, the user is encouraged to try to correct the interference by one or more of the following measures:

- Reorient or relocate the receiving antenna.
- Increase the separation between the equipment and receiver.
- Connect the equipment into an outlet on a circuit different from that to which the receiver is connected.
- Consult the dealer or an experienced radio/TV technician for help.

Regulatory (cont'd)

FCC notes

The FrontRow To Go active learning system is approved by the FCC (Federal Communications Commission). The use of the system may be governed by specific FCC rules and FCC licensing or notifications may be required. Consult your local FCC office for detailed information.

Phonic Ear FM receivers and FM transmitters, when required, are approved by the Federal Communications Commission (FCC) in the U.S. and Industry Canada. Other government approvals are available upon request. (Other international regulations may also apply.)

Any changes or modifications made to any government-approved element of this instrument, without the express approval of Phonic Ear Inc in writing, could void the user's authority to operate those elements of the system.

Part 95

This transmitter is authorized by rule under the Low Power Radio Service (47 CFR Part 95) and must not cause harmful interference to TV reception or United States Navy SPASUR installations. You do not need an FCC license to operate this transmitter. This transmitter may only be used to provide auditory assistance to persons with disabilities, persons who require language translation, or persons in educational settings; health care services to the ill; law enforcement tracking service under agreement with a law enforcement agency; or automated maritime telecommunication system (AMTS) network control communications. Two-way voice communications and all other types of uses not mentioned above are expressly prohibited.

Regulatory (cont'd)

This device may not cause interference and must accept any interference received, including interference that may cause undesired operation.

These devices may not interfere with TV reception or Federal Government radar.

IC notes

This Class B digital apparatus complies with Canadian ICES-003.

Cet appareil numérique de la classe B est conforme à la norme NMB-003 du Canada.

The term "IC:" before the radio certification number only signifies that Industry of Canada technical specifications were met.

If TV channel 13 is used in the area, the installer shall reduce or adjust the RF radiated power so that near-by TV channel 13 receivers do not receive radio interference from the system installed. Suggestions: A test

with a TV receiver equipped with "rabbit-ear antenna" and tuned to channel 13 should be conducted, at the perimeter of the users' intended coverage area and not overlapping other user's areas without the latter's consent. If this does not solve the problem, a channel near the 217 MHz edge and not near 216 MHz should be tried.

Notes



u.s.a. **800.227.0735**, then press **5** • canada **800.340.9894** • international **+45 3917 7101**

© 2013 FrontRow Calypso LLC Phonic Ear, FrontRow, Calypso and the names of Phonic Ear, Calypso, and FrontRow products are trademarks or registered trademarks of FrontRow Calypso LLC in the U.S. and other countries. Product specifications and accessories subject to change without notice.